

1160 Technical Binder

2025 - 2026 Rebuilt

[Ti]-Rex



Table of Contents

Design Philosophy.....	3
Initial Prototypes.....	4
In-Season Upgrades.....	6
Intake.....	7
Agitator.....	8
Hopper & Gate.....	9
Transport.....	10
Shooter.....	11
Drivetrain.....	12

Design Philosophy

Our Team Motto: “Feelings are important, but it's the Physics that matters.”

- While what we feel and think may happen plays a role in our design process, at the end of the day, we have to test and see how the physics play out

Goals:

- Needs:
 - Swerve drivetrain
 - Even with the return of the terrain with the bump, the flexibility swerve offers makes it an ideal drivetrain option
 - Score ~30 balls per shift
 - This target was set by the 360 fuel to achieve $\frac{1}{3}$ of the Supercharged RP threshold
 - Hold at least 45 fuel
 - Active intake
 - Increases consistency and reduces hopper fill-up time
 - Go over the bump
- Nice to have:
 - Fit under the trench
 - While this increases the options our driver can pick to go through, it also limits our hopper capacity
 - Move while shooting
 - This allows for more dynamic gameplay and strategy, allowing you to slowly sweep your alliance side as you shoot
- Omissions
 - Climb
 - Given the fact that we have 30 seconds of endgame, we found it more worthwhile to not climb and maximize fuel scoring

Initial Prototypes

Starwheel + Roller Intake

- While the star wheels provided excellent grip for initial contact with the fuel, we found that the star wheels would compress too much and jam the intake or not provide enough momentum for the fuel to go further into our hopper
- The Cat-Tongue roller was good at maintaining grip, but the polycarbonate roller lacked any compliance with the fuel, putting more strain on the motor. We felt that, given the high volume intake required for this year's game, we would rather have compliant wheels

Pivoting Intake

- While simpler than our current rack-and-pinion intake, the pivoting intake had a large footprint in the hopper and would have added complexity to our extendable hopper. Our main goal was hopper capacity and smooth integration.

Belt Agitator

- We found the fuel to be too heavy and dense for the belt to transport the fuel effectively. Additionally, the fuel would sit in place in the middle of the belt, causing a dead zone. While this could be solved with specific tensioning, we felt that it would be simpler to use a roller floor.

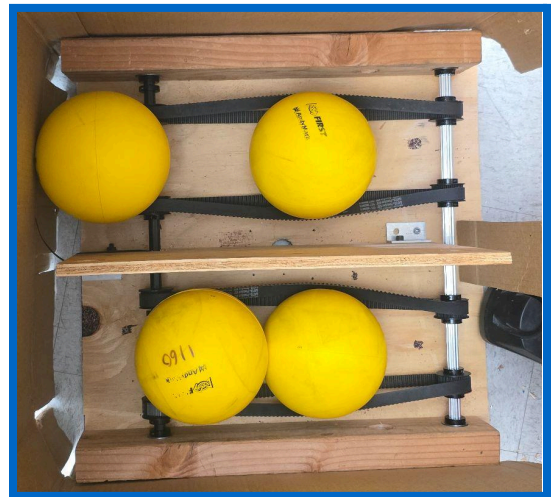

Spindexer

- While our initial prototype seemed to be promising, the spindexer design would have limited our shooter to a single shooter

Compliant Wheel Transport

- The compliant wheel transport was good for our prototype shooter, but having a set of rollers and wheels for a taller shooter would have taken up a larger footprint and increased our weight.

Hooded Shooter

- We found that while the hooded shooter was good at shorter ranges, we needed to have an active element to increase our throughput and make our output distances more consistent.

S-shooter

- We initially prototyped with a shooter that had the ball travel in an “S” path through the robot. We decided to pivot to a “C-shooter” to avoid the possibility of our fuel being blocked by defense and for easier transport to shooter integration.

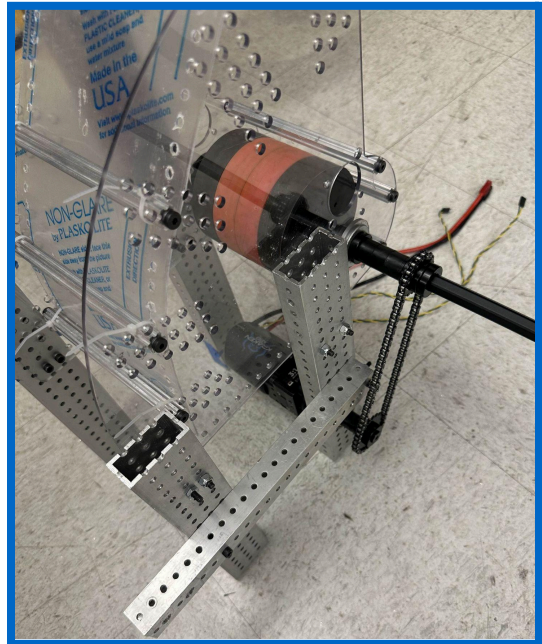

In-Season Upgrades

Passive Intake Kicker

- One of our bottlenecks seen throughout the regular season is our ability to intake enough fuel to fully utilize our large hopper. The addition of our passive kicker provided more compression as the fuel goes up the roller, which makes it easier to intake more fuel

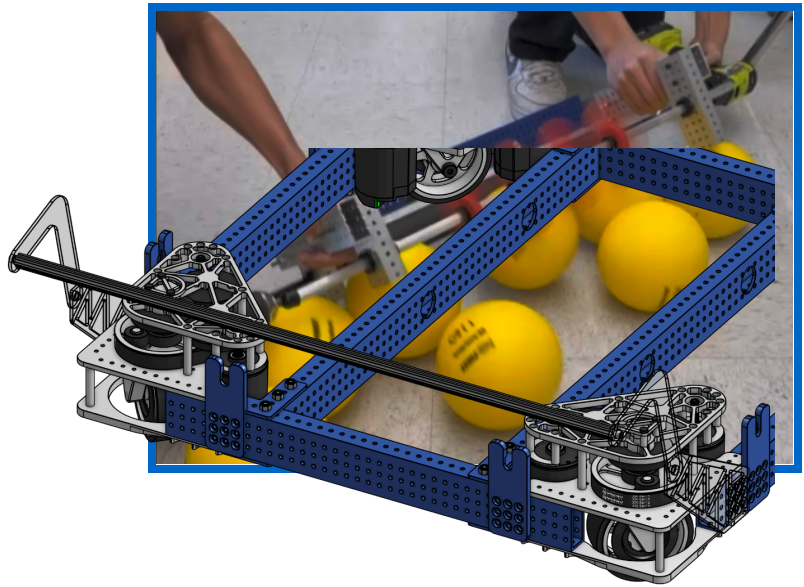

Varying Gate Wheels

- The increasing diameters of the wheels for our intake act like an active funnel, increasing the throughput of fuel into our shooter

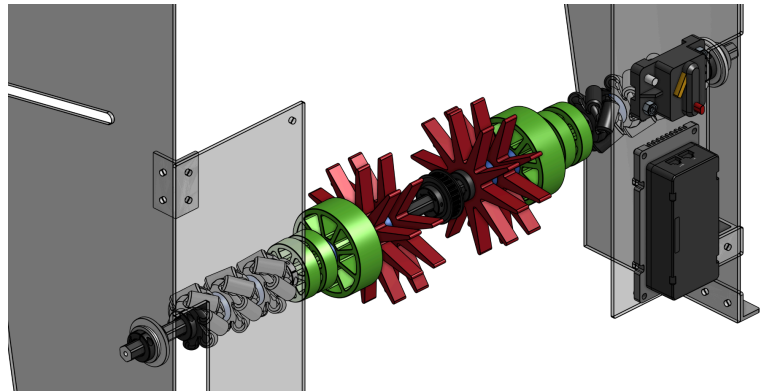

Lower Compression Top Roller

- Another bottleneck seen was the high compression with our top rollers. In order to be able to shoot 2 fuel at the same time and increase our overall BPS and throughput, the 2" stealth wheels were changed for 1 5/8" compliant wheels to decrease our overall compression.

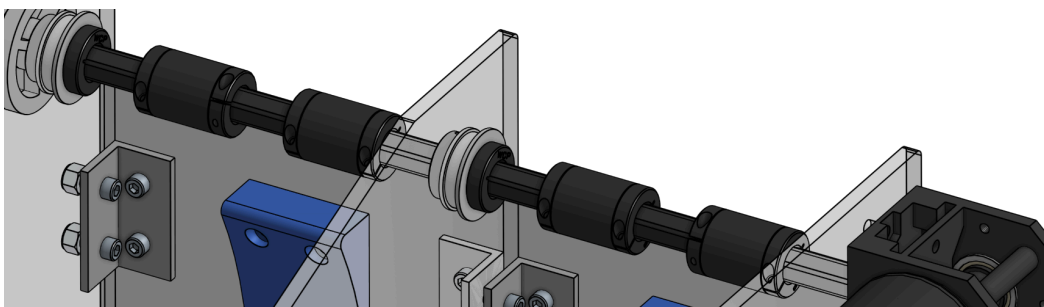

Intake

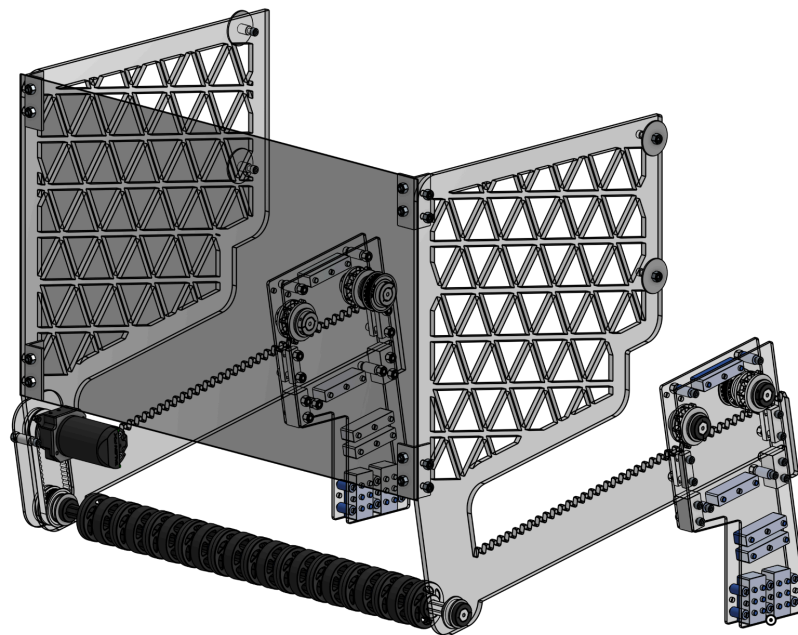

Construction

- Rack, Pinions, and External Hopper Side Panels are made of 1/4" polycarbonate
- Pinon Housings are made of 1/8" polycarbonate
- Custom 3D printed (PLA) spacers and Custom *Teflon* Blocks are between the housing plates

Power

- A Kraken X60 with a 3:1 reduction powers our roller with 2" compliant wheels
- A Neo 1.1 with a 9:1 reduction powers the rack and pinion deployment through a series of belts

Advantages

- The rack and pinion allows for a linear deployment, simplifying the geometries for an extendable hopper and reducing the footprint of the intake when stowed
- Polycarbonate panels are lightweight and allow our intake to be semi-flexible, mitigating the risk of deformation or breaking the intake during a collision

Agitator

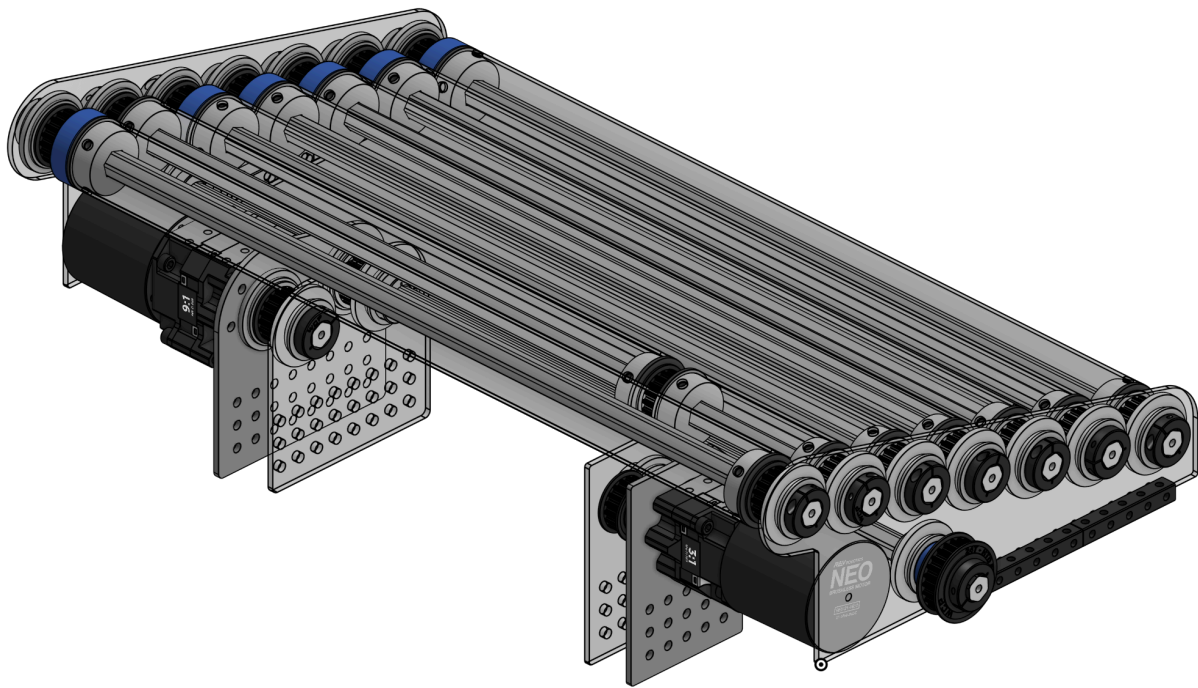

Construction

- Agitator walls are made of 1/8" polycarbonate
- Rollers are 1.5" diameter polycarbonate tubes with Cat-Tounge Tape
- Custom 3D printed 18t pulleys power the rollers with alternating belts
- The roller plane is at a 14° decline
- Nut strips and motor plates are used for mounting

Power

- A NEO 1.1 with a 5:1 reduction powers all of the rollers

Advantages

- The polycarbonate rollers are lightweight and provide a large active surface area that keeps the Fuel moving towards the shooter
- The Nut strips and motor plates make the design modular for easy repairs

Hopper & Gate

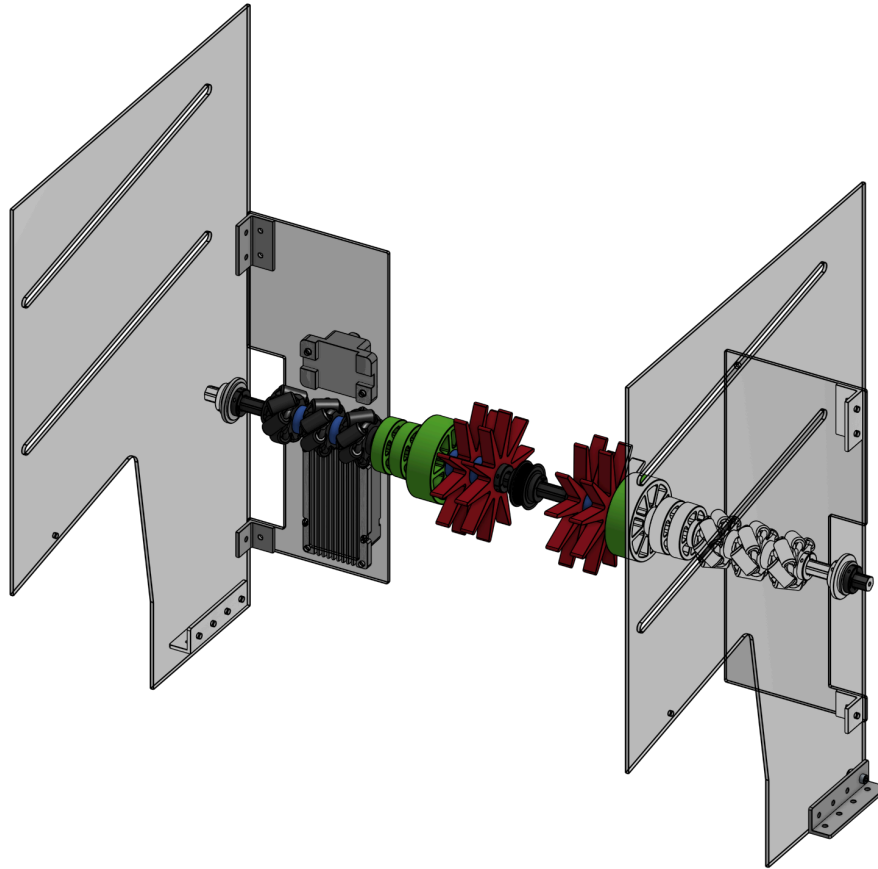

Construction

- Hopper walls are made of 1/8" polycarbonate sheets
- Max hopper height from the ground is 28"
- 2" mecanum wheels on the side and 3" 35A compliant wheels in the middle

Power

- A NEO 1.1 with a 5:1 reduction powers the gate and transport mechanism

Advantages

- The mecanum wheels help guide the fuel into the middle, where the compliant wheels provide grip and actively funnel fuel into the transport
- Funnel plates also assist the mecanum wheels to guide the fuel into transport
- Rails provide smooth and accurate guidance for extendable hopper deployment

Transport

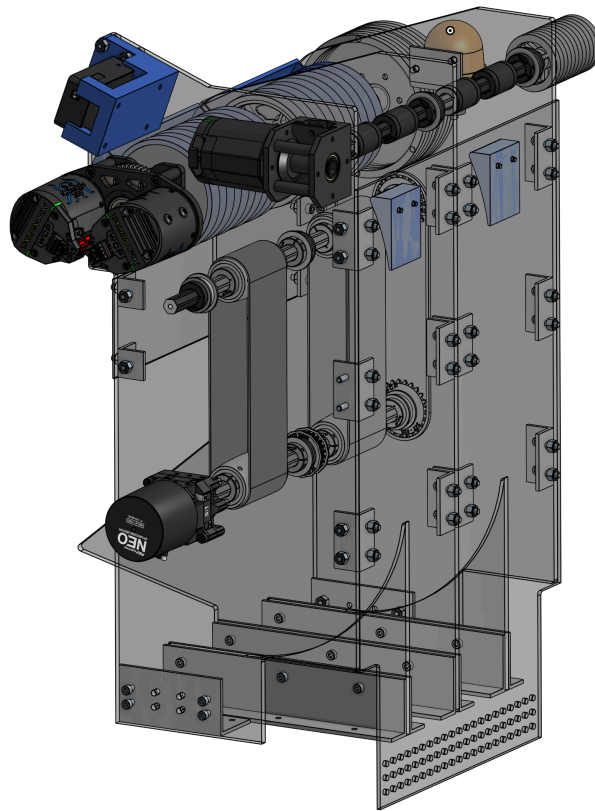

Construction

- Ramp and Shooter assemblies are all made of 1/4" polycarbonate
- Custom 3D printed crowned pulleys
- Belts are 2" wide polyurethane belts

Power

- A NEO 1.1 with a 3:1 reduction powers the gate and transport mechanism

Advantages

- The polyurethane belts provide a good grip on the fuel
- Only using one belt over a set of rollers or wheels reduces the overall footprint, allowing us to maximize hopper capacity

Shooter

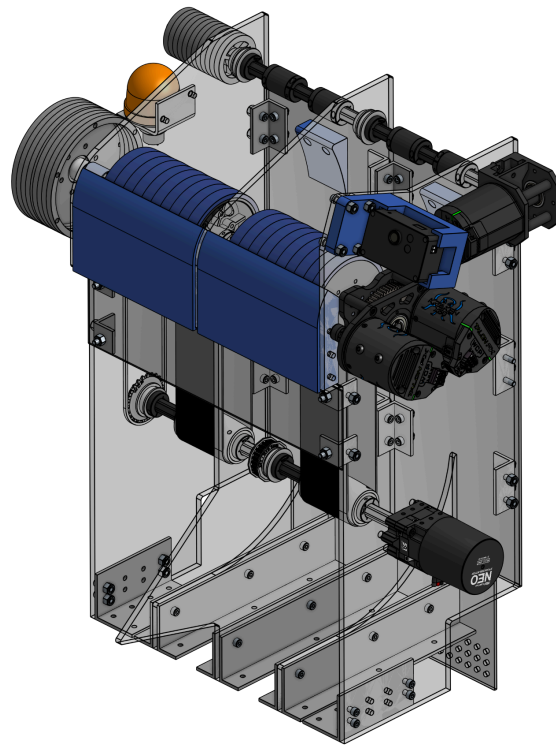

Construction

- Side walls are made of 1/4" polycarbonate sheets
- Steel flywheels
- Bottom roller is made of 4" stealth wheels, and top roller is made of 1 5/8" compliant wheels

Power

- 2 Kraken X60s power our bottom roller, and 1 Kraken X60 powers our top roller

Advantages

- Flywheel masses keep the moment of inertia high, making the RPM more consistent with high-volume shooting
- The dual shooter design allows us to prevent jams while keeping the shooting throughput high

Drivetrain

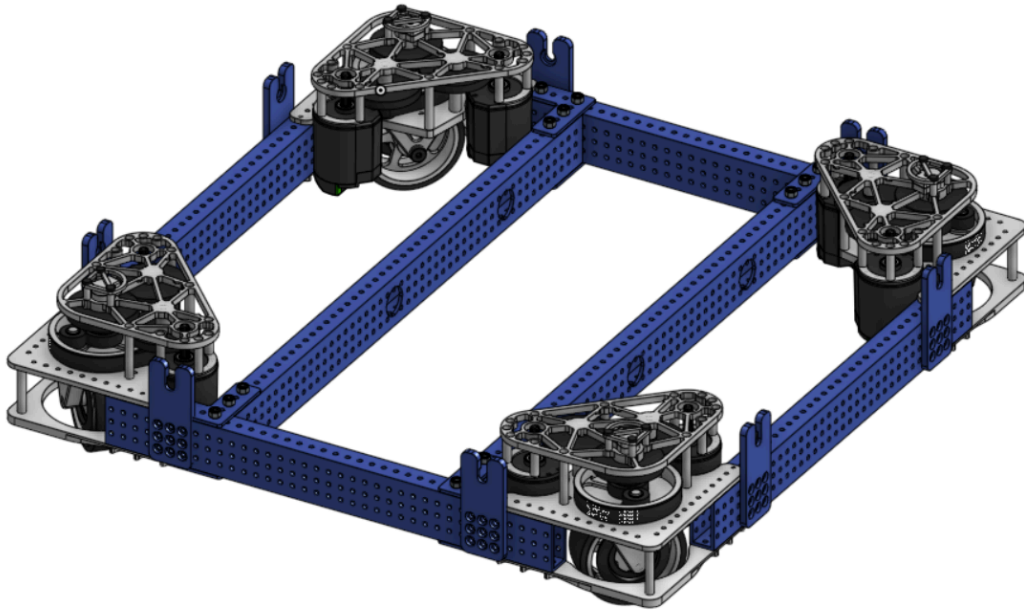

Construction

- 2" x 1" metal allows for ease of mounting brackets while providing strength
- 25" Superstructure allows for stability and mounting of subsystems, 1" holes cut for wiring
- 8 1/4" Aluminum Bumper Mounting Brackets

Power

- 2 Kraken X60s power per swerve module for a total of 8 Kraken X60s
- SDS Mk4i Swerve Module, L2 Gear Ratio

Advantages

- The swerve drivetrain allows for increased mobility and speed
- Square drivetrain allows for ease of driving and programming orientation due to the nature of the swerve
- L2 Gear Ratio allows for a good balance of torque and speed against defense